

BULKHEAD JACK RECEPTACLE
COMBINATION SEAL WITH SOLDER POT CONTACT

R161.606.050

Series : N

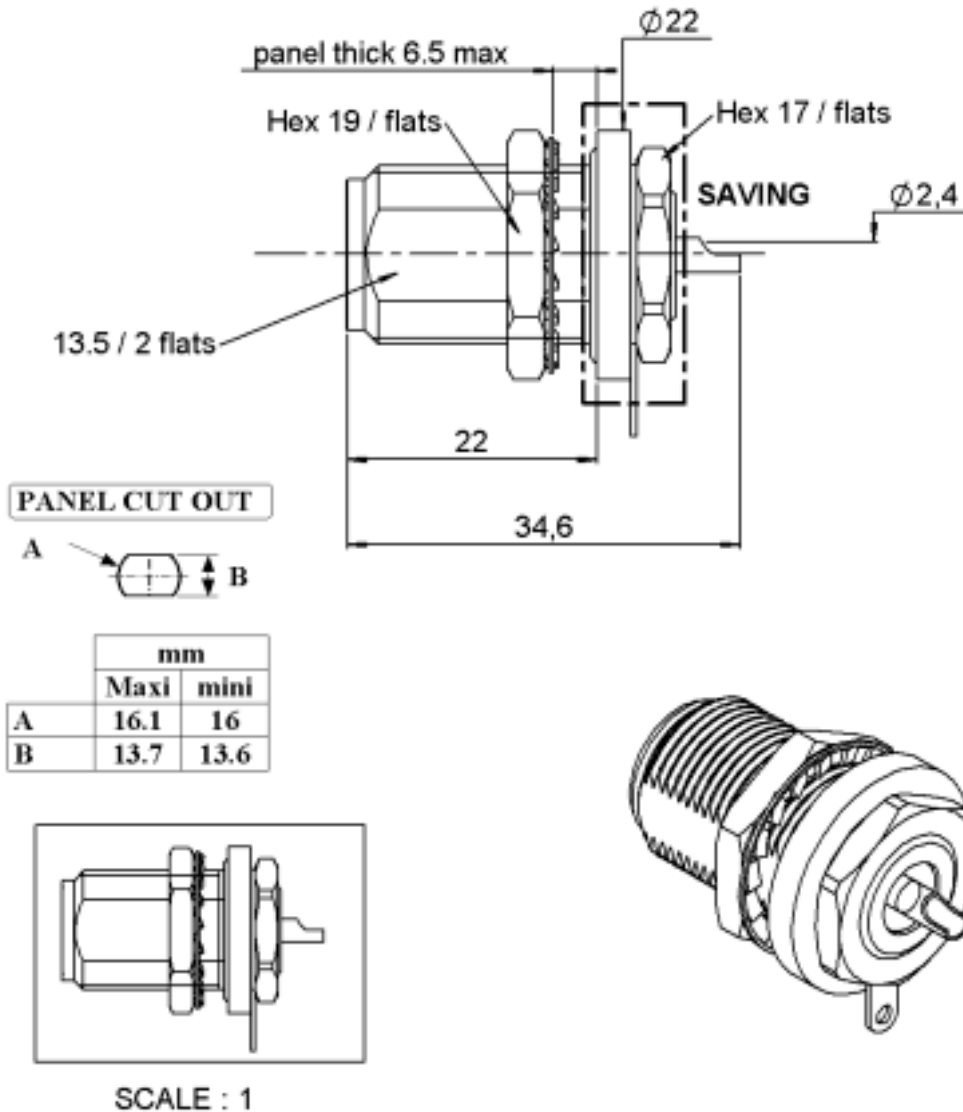

All dimensions are in mm.



COMPONENTS	MATERIALS	PLATINGS (µm)
BODY	BRASS	BLACK-CHROMIUM 0.2 OVER NICKEL 2
CENTER CONTACT	BERYLLIUM COPPER	GOLD 0.5 OVER NICKEL 2
OUTER CONTACT	BRASS	BBR 2
INSULATOR	PTFE	
GASKET	SILICONE RUBBER	
OTHERS PARTS	BRASS	BBR 2
-	-	-
-	-	-

Issue : 0245 F

In the effort to improve our products, we reserve the right to make changes judged to be necessary.



BULKHEAD JACK RECEPTACLE

R161.606.050

COMBINATION SEAL WITH SOLDER POT CONTACT

Series : N

PACKAGING

SPECIFICATION

Standard	Unit	Other
-	'W' option	Contact us

ELECTRICAL CHARACTERISTICS

ENVIRONMENTAL

Impedance		50 Ω
Frequency		0-11 GHz
VSWR	NA +	0.000 x F(GHz) Maxi
Insertion loss		NA √F(GHz) dB Maxi
RF leakage	- (101 - F(GHz)) dB Maxi
Voltage rating		1400 Veff Maxi
Dielectric withstanding voltage		2500 Veff mini
Insulation resistance		5000 MΩ mini

Operating temperature	-55/+155 ° C
Hermetic seal	NA Atm.cm3/s
Panel leakage	IP 67

OTHERS CHARACTERISTICS

Assembly instruction

Others :

MECHANICAL CHARACTERISTICS

Center contact retention		
Axial force – Mating end		27 N mini
Axial force – Opposite end		27 N mini
Torque		NA N.cm mini
Recommended torque		
Mating		NA N.cm
Panel nut		500 N.cm
Mating life		500 Cycles mini
Weight		38.800 g

Issue : 0245 F

In the effort to improve our products, we reserve the right to make changes judged to be necessary.

